



InSwitch Industrial Ethernet Switch

User's Manual for ISF Series Products

V3.2



InHand Networks



User's Manual for InSwitch ISF Series Products

Copyright Statement

copyright © 2016 InHand Networks

All right reserved and no reproduction allowed without permission.

Trademark

InHand and InHand Networks are registered trademarks of INHAND Network Co., Ltd and all other trademarks or registered trademarks in the manual belong to corresponding manufacturers.

Disclaimer

InHand shall not be taken responsible for any modification of contents of the manual made without permission.

This manual may contain some technical or printing errors due to human error. These errors will be corrected periodically and will be avoided in reprint.

InHand reserves hereby the right to amend the manual without further notice to users.

Please log in our website or contact our business agent directly for revision status of the manual.

Contact Information for Technical Support

3900 Jermantown Rd., Suite 150

Fairfax, VA 22030

USA

T: +1-703-348-2988

F:+1-703-348-2988

support@inhandnetworks.com

www.inhandnetworks.com

Safety Instructions

The product has excellent and reliable performance within designed application range, but man-made damage or destruction shall be prevented.

Please read the manual carefully and keep the same properly for further reference.



Please pay attention to the follows when using the equipment:

- Do not place the equipment close to water or at wet places.
- Do not place anything on power cable, which shall be kept out of touch.
- Do not tie or wrap power cable in order to prevent fire.
- Connection of power cable and other connecting pieces of the equipment shall be secure and shall be inspected regularly.
- Please keep socket and plug of optical fiber clean. Looking into cross section of optical fiber directly is strictly prohibited during operation of the equipment.
- Keep the equipment clean and wipe with soft cotton cloth when necessary.
- Unless other wise instructed in the manual, please do not try to repair the equipment by yourself.

Please disconnect power source immediately under the following circumstances and then contact us.

- Entering of water into the equipment.
- Crash damage of the equipment or crack of casing.
- Abnormal equipment working state or complete change in displayed performance.
- Gas, smoke or noise generated by the equipment.

Brief Introduction of the Manual

The manual is applicable for type ISF2008D, ISF2016D and ISF3010D of ISF series

products.

The manual contains the following chapters:

- Packing list. List of goods that should be contained in packing box of the equipment.
- Product introduction. Brief introduction of the product and outstanding features .
- Front panel and dimension. Front panel diagram and dimension of each and every product of ISF series are provided.
- Installation .Installation method is given in details to guide users to install the equipment correctly.
- Cable connection. Description of correct methods for connection of power cable and communication cable.
- Introduction of functions. Detailed description of definitions of indication
- Specifications and parameters. Description of codes and standards observed by the product, and product specifications and parameters.
- Networking mode. Enumerate briefly common networking modes of ISF series switch.

Readers are instructed to read the contents carefully when the following icons are met in the manual. Introductions of these icons are given in the following table.



Note: Supplementary to main text.



Warning: Function may not be available or damage of equipment may occur if operation instruction is not followed.



Danger: Bodily injury may occur if operation instruction is not followed.



Contents

User's Manual for ISF Series Products	1
Safety Instructions	2
Brief Introduction of the Manual	3
I. Packing List	6
II. Product Introduction.....	7
2.1 General.....	7
2.2 Outstanding Product Features	8
III. Front Panel and Dimension.....	9
3.1 ISF2008D.....	9
3.2 ISF2008D.....	11
3.3 ISF3010D.....	14
IV. Installation.....	15
4.1 Instruction for Guide Rail Installation	15
V. Cable Connection	16
5.1 10/100Base-T(X) port.....	16
5.2 100Base-FX port.....	18
5.3 1000Base-X,1000Base-T(X) SFP Port.....	19
5.4 Power Source	20
5.5 Earthing Protection	22
5.6 Alarm.....	22
VI. Introduction of Functions.....	23
6.1 Introduction of Indication Lamps.....	23
6.2 Dip Switch.....	24
6.3 Introduction of Alarm.....	25
6.4. Introduction of Ring Network.....	26
6.4.1 Configuration of ISM Network Management Switch	27
6.4.2 Default Ring Port of ISF Switch	28



VII. Specification and Parameters.....	28
VIII. Networking Mode	29
8.1 Networking of Single Set of Equipment	29
8.2 Networking of Multiple Sets of Equipment	30
8.2.1 Ring Network.....	30
8.2.2 Star Network	31

I. Packing List

Common accessories required by users at site are provided for each set of ISF series products (as shown in list of standard accessories). Please check our package carefully after taking delivery and contact InHand sales personnel timely if any missing or



damage is found.

In addition, InHand can also provide users with optional accessories as per different field conditions and characteristics. Please refer to list of optional accessories for details.

Standard Accessories

Accessory	Qty.	Description
Industrial Ethernet switch	1 Set	InSwitch ISF series switch
Product document	1 Set	Optical disk
DIN- rail mounting accessories	1 Piece	Fixed type switch
Product warranty	1 Sheet	Warranty period is 5 years.

Optional accessories

Accessory	Qty.	Description
220VAC-24VDC adapter	1 Set	InSwitch ISF series switch
1m optical jumper wire	1 Piece	For testing by users
Installation accessory	1 Set	1 piece of wall-mounting accessory and 4 pieces of screw

II. Product Introduction

2.1 General

ISF series switch is of high performance, low energy consumption and ring network type industrial Ethernet switch specially developed for industrial applications. It provides strong, easy to use and safe switching infrastructure. ISF series products



have adopted industrial design and comply with industrial codes and standards; it simplifies deployment, management and replacement of industrial network; it also provides excellent network security on the basis of open standards/protocols. ISF series switches are ideal products for supporting application of industrial Ethernet networks such as deployment in wind power generation, distribution network automation, transformer substation, factory automation, intelligent transportation system (ITS) and application in other severe conditions and environment. ISF series products are of ring network type products.

2.2 Outstanding Product Features

High-performance Ethernet switch technology:

- Supporting IEEE802.3/802.3u/802.3x
- Supporting flow control (full duplex and half duplex flow control)
- Supporting automated negotiation
- Supporting broadcast storm protection
- Store-and-forward switching mode
- 10/100M full duplex/half duplex MDI/MDI-X self adaptive

Reliable and steady operation under severe electrical environment:

- Passed high-standard electromagnetic compatibility test
- Zero packet loss under intensive electromagnetic interference

Suitable for application under various severe conditions and environment:

- Working temperature: -40~85 °C
- Relative humidity: 5%~95% (free of condensation)
- IP40 protection class, fully enclosed and seamless type metal cabinet, and fanless cooling.

Ring network technology guarantees network stability and security:

- Supporting ring network, no configuration required for ring formation, capable of plug and play.
- Provided with iRing Ethernet ring network protection protocol, with full-network recovery time <50ms.

Satisfying industrial installation requirement:

- Standard industrial DIN rail or wall-mounting type installation
- Industrial power source terminal or I/O terminal

- PCB protection coating available

Network reliability enhanced via redundancy and alarm:

- Double-power-source redundant input
- Warning can be produced via relay at power supply failure and interruption of port connection

VLAN (IEEE 802.1q):

- Network planning can be simplified, broadcasting domain can be restricted and LAN security can be enhanced and for supporting of VLAN can be achieved by way of custom making.

III. Front Panel and Dimension

3.1 ISF2008D

Front Panel Layout

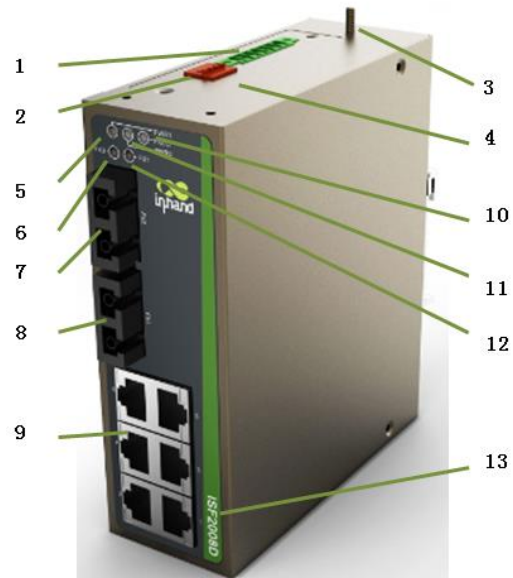

-
1. Power source connection and alarm connection terminal
 2. Dip switch
 3. Earthing screw for protective earthing
 4. Cover plate
 5. Power source 1 indication lamp
 6. FX2 LINK/ACT indication lamp
 7. FX2100M SC /ST optical interface FX2
 8. 100M SC /ST optical interface FX1
 9. 10M/100M RJ45 interface
 10. Alarm indication lamp
 11. Power source 2 indication lamp
 12. FX1 LINK/ACT indication lamp
 13. Film paste LOGO

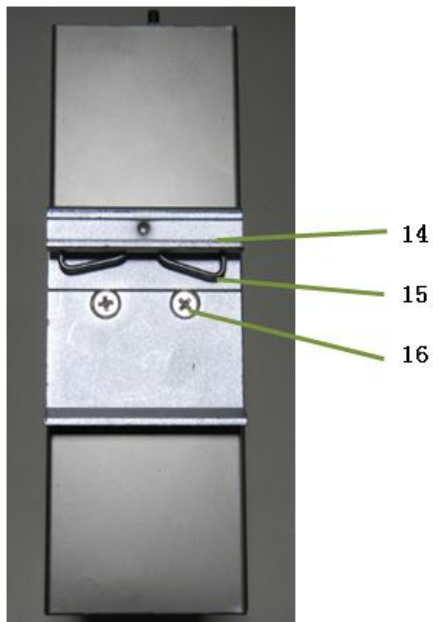

14. DIN- rail
15. Clamp spring
16. DIN- rail fixing screw

Structural Dimension

(Unit: mm)

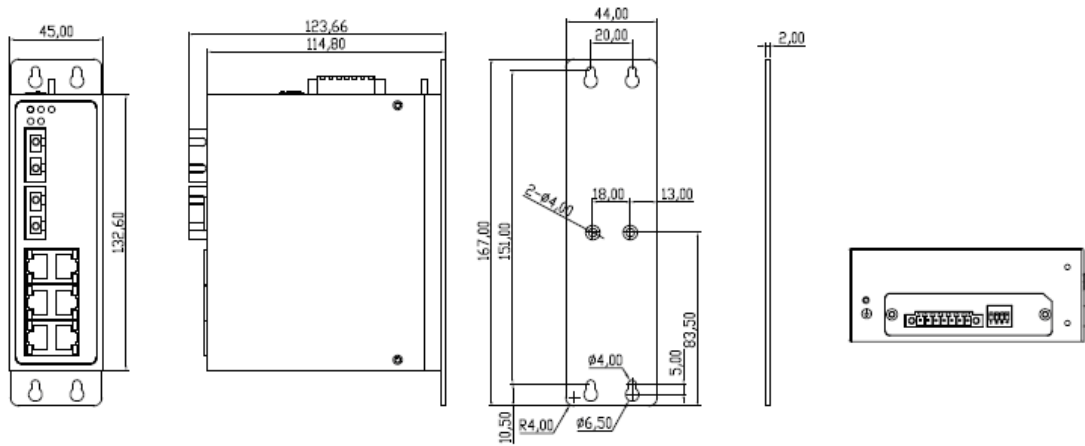

Wall Mounting Diagram

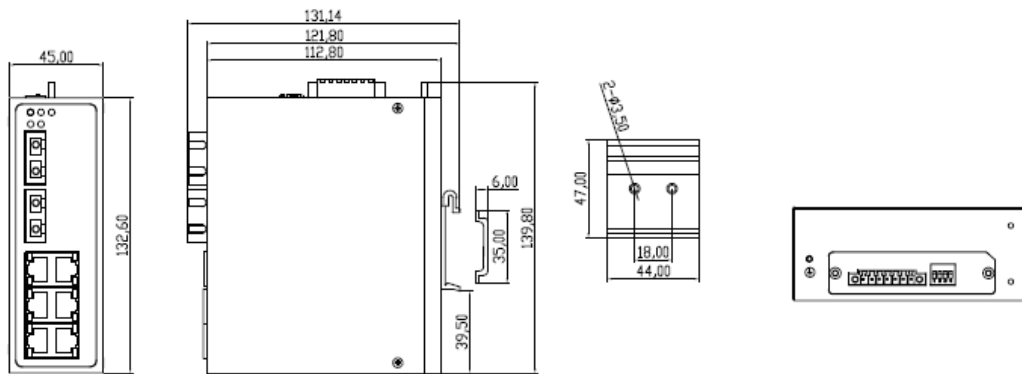

Clamp Rail Mounting Diagram

3.2 ISF2016D

Front Panel Layout

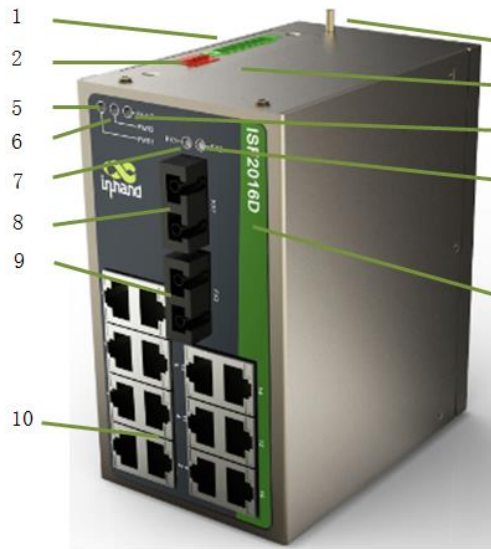

1. Power source connection and alarm connection terminal

2. Dip switch

3. Earthing screw for protective earthing

4. Cover plate

5. Power source 1 indication lamp

6. Power source 2 indication lamp

7. Optical port FX1 LINK/ACT indication lamp

8. 100M SC /ST optical interface FX1

9. 100M SC /ST optical interface FX2

10. 10M/100M RJ45 interface

11. Alarm indication lamp

12. Optical port FX2 LINK/ACT indication lamp

13. Film paste LOGO

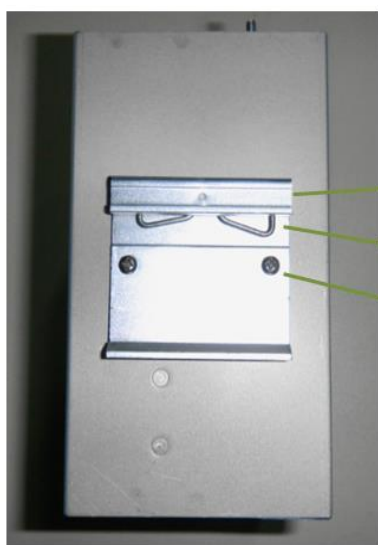

14. DIN- rail

15. Clamp spring

16. DIN-rail fixing screw



Structural Dimension

(Unit: mm)

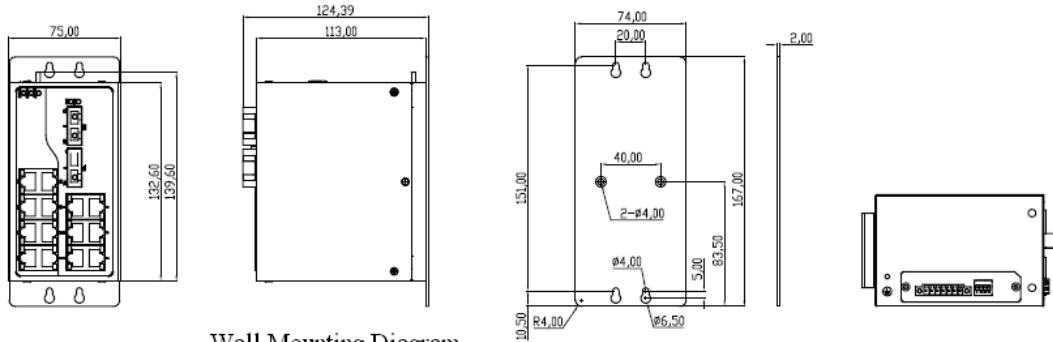

Wall Mounting Diagram

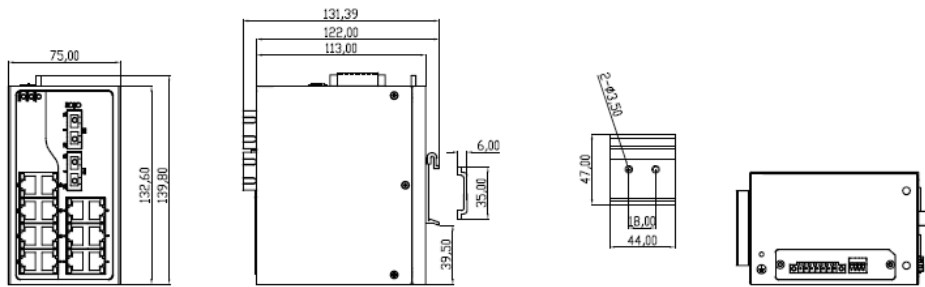

Clamp Rail Mounting Diagram

3.3 ISF3010D

Front Panel Layout

Structural Dimension

(Unit: mm)

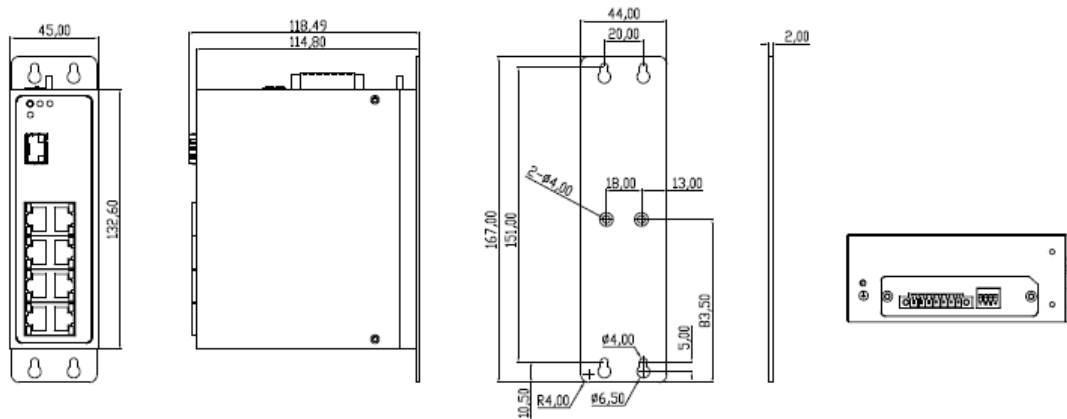

Wall Mounting Diagram

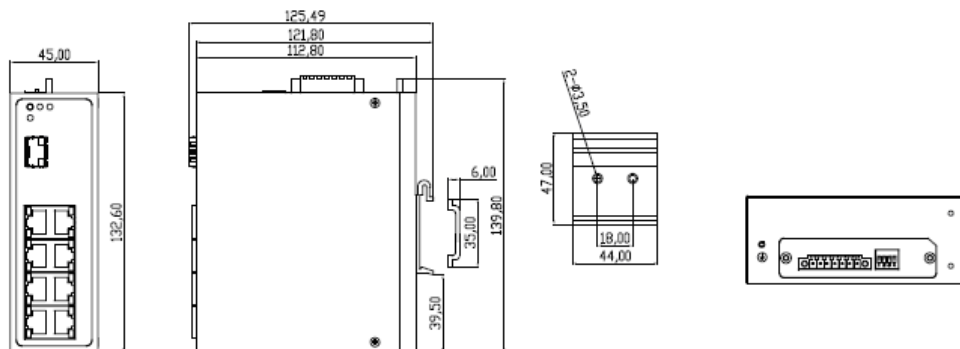

Clamp Rail Mounting Diagram

IV. Installation

Installation Requirement

- Power source requirement: 24VDC(12~48VDC). Attention shall be paid to power voltage class.
- Environment requirement: Working environment: $-40^{\circ}\text{C} \sim 85^{\circ}\text{C}$, storage environment: $-40^{\circ}\text{C} \sim 85^{\circ}\text{C}$, relative humidity 5%~95% (no condensation).
- Earthing resistance requirement: $<1\Omega$.
- Inspect appropriateness of laying of optical cable and connection of optical joints as per configuration requirement of the contract.
- Avoid direct sunshine and keep away from heat source or intensive electromagnetic interference area.
- ISF switch product is installed on industrial guide rail.
- Inspect for availability of cable and joints required for installation.

4.1 Instruction for DIN- Rail Installation

Step 1

Press clamp spring of guide rail of the switch on guide rail of equipment cabinet at a dip angle of 30 degree as shown in the diagram:

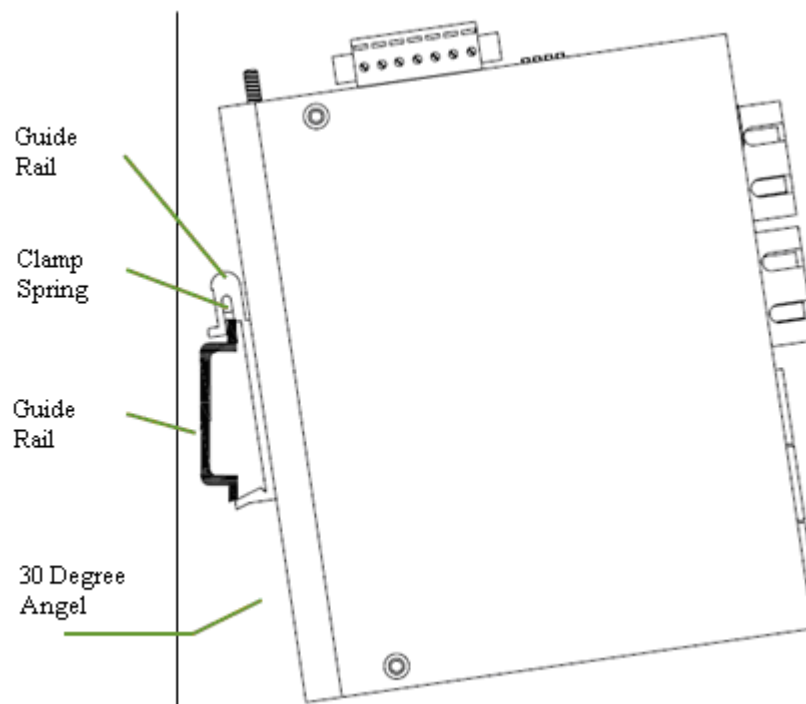

Step 2

Press the switch with force to clamp on guide rail of equipment cabinet at a dip angle of 60 degree as shown in the following diagram:

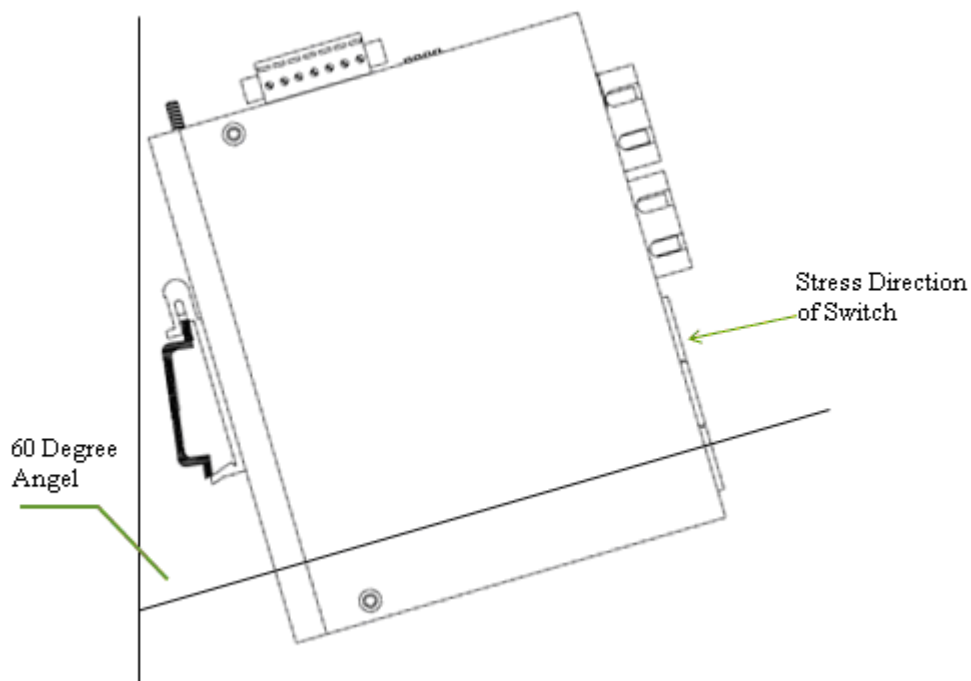

V. Cable Connection

5.1 10/100Base-T(X) port

RJ45 interface is used for 10/100Base-T(X) port and all ports of the type support MID/MDI-X self adoption. RJ45 ports of the equipment at both ends can be connected with straight-through cable or with cross-over cable.

! **Attention:**

Standard CAT5 or CAT5e types twisted pair cable shall be used.

- Definition of RJ45 interface

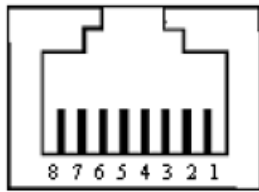

- Description of pins on 10/100Base-T(X) port

Pin	MDI	MDI-X
1	Positive terminal for data transmission (TD+)	Positive terminal for data receiving (RD+)
2	Negative terminal for data transmission (TD-)	Negative terminal for data receiving (RD-)
3	Positive terminal for data receiving (RD+)	Positive terminal for data transmission (TD+)
6	Negative terminal for data receiving (RD-)	Negative terminal for data transmission (TD-)
4,5,7,8	Not used	Not used

- 100Base-TX direct connection

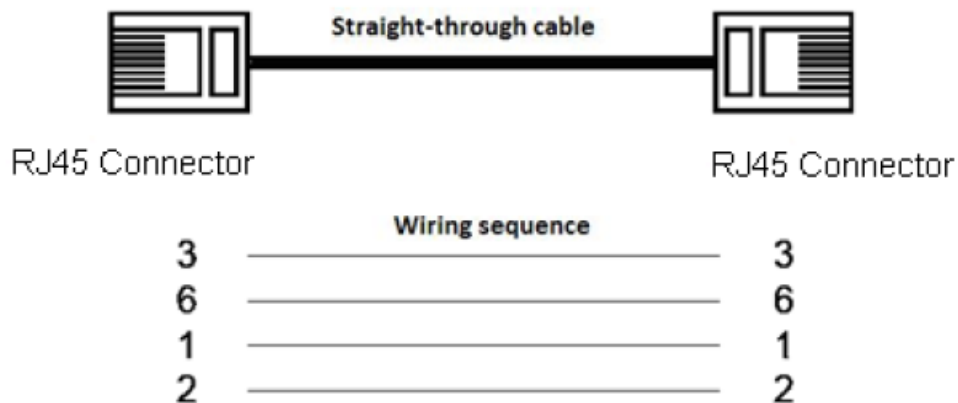

- 100Base-TX cross connection

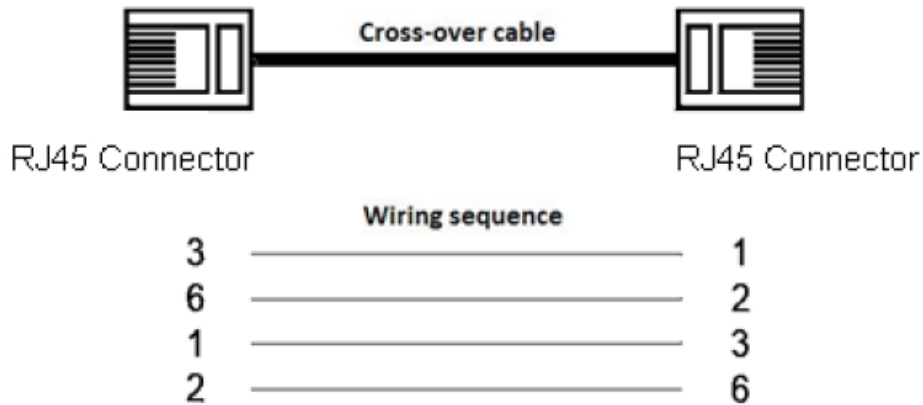

5.2 100Base-FX port

Optical cable plug shall be plugged into each optical port gently and rough plugging operation is strictly prohibited at wiring of optical cable.

Correct wiring sequence shall be ensured for connection of equipment at both ends during optical cable connection, i.e. Tx port of the home terminal shall be connected to Rx port of the opposite terminal; and Rx of the home terminal shall be connected to Tx port of the opposite terminal. SC port is taken as an example hereunder for wiring sequence of optical cable connection (connection of ST, FC, LC ports are same with SC port).

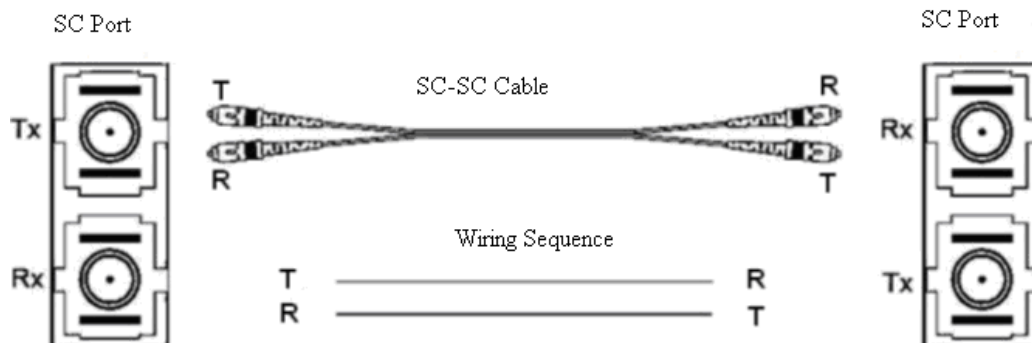

! Attention:

When ports at both ends are connected but corresponding optical port indication lamp of the home optical port is not lit, it may indicate that wiring sequence is in error, which can be corrected by simply exchanging home port RX cable with TX cable.

5.3 1000Base-X,1000Base-T(X) SFP Port

SFP port can support gigabit SFP optical module (1000Base-X) or gigabit SFP electric module (1000Base-T(X)), which shall be correctly chosen by user as per actual requirement.

- Gigabit SFP optical module

Typical gigabit SFP optical module is shown in the following diagram.

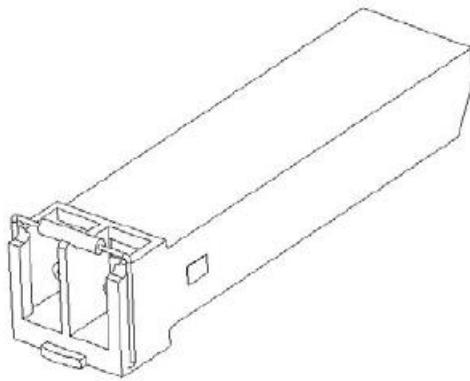

LC interface is adopted for gigabit SFP optical module, including receiving port (RX) and transmission port (TX).

Optical cable connection steps:

Step 1: Plug SFP optical module into SFP slot.

Step 2: Connecting optical cable. Connect RX of the home port to TX of the opposite port, and connect TX of the home port to RX of the opposite port, as shown in the following diagram:

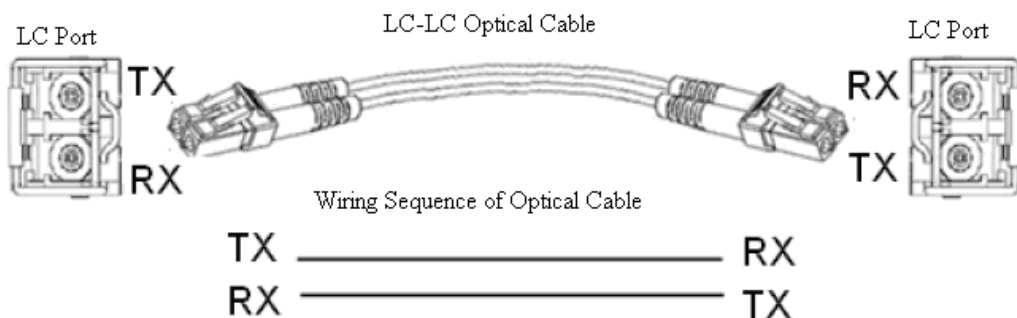

! Attention:

When ports at both ends are connected but corresponding optical port indication lamp of the home optical port is not lit, it may indicate that wiring sequence is in error, which can be corrected by simply exchanging home port RX cable with TX cable.

● Gigabit SFP electric module

Typical gigabit SFP electric module is shown in the following diagram.

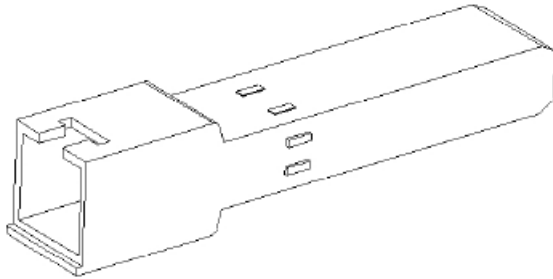

Steps for connection of ports of SFP electric module are as the follows:

Step 1: Plug SFP electric module into SFP slot.

Step 2: Connect ports at both ends with Ethernet cable.

! Attention:

CAT5, CAT6 or CAT7 types of twisted pair cable shall be used.

5.4 Power Source

Power source connection of the switch is of terminal connection mode, therefore, power cable of power adaptor shall be connected to terminal prior to use. Two-way power source redundant connection is provided for the switch, connection of one way or two ways can be selected at application of the switch by users as per requirement.

Wiring of terminal blocks is shown in the following schematic diagram.

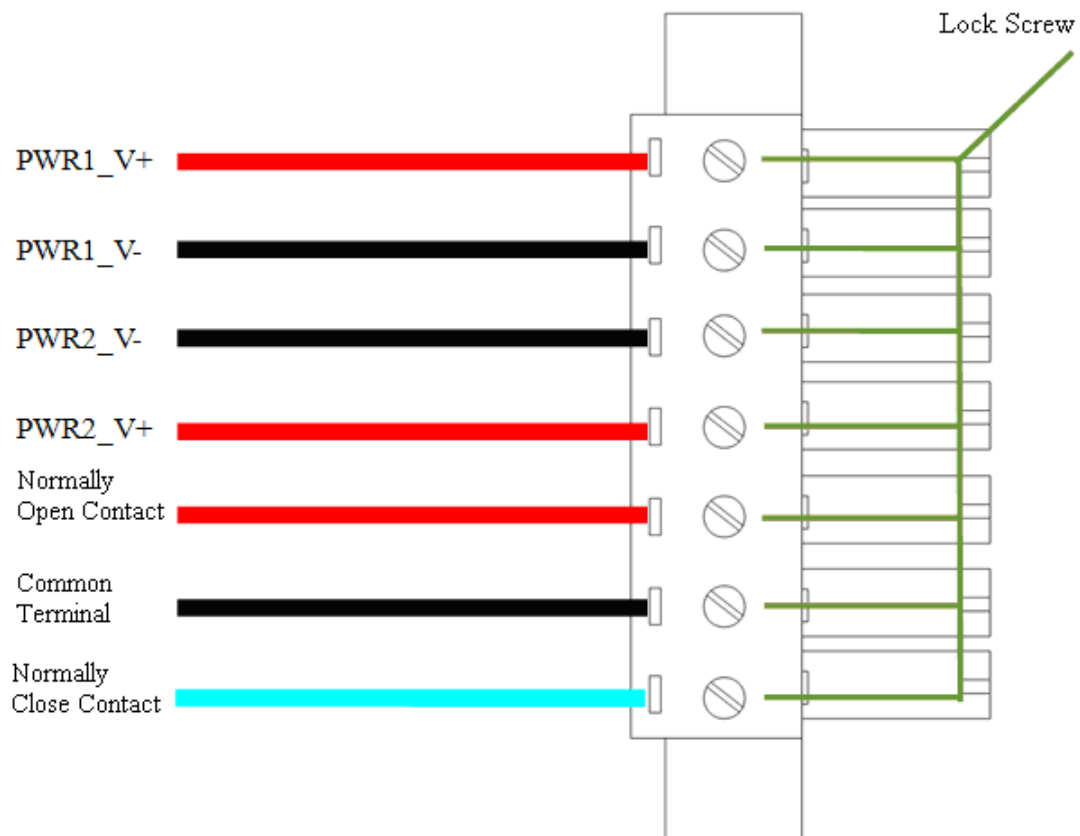

Terminal blocks is shown in the following schematic diagram.

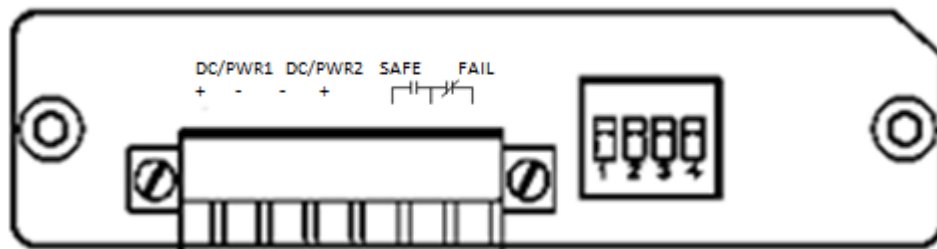

Wiring Method:

Step 1: Take off the terminal from the switch.

Step 2: Plug power cable into the terminal before tightening screw.

Step 3: Install the terminal back onto the switch before fastening with set screw.

Method for screw fixing is shown in the following diagram.

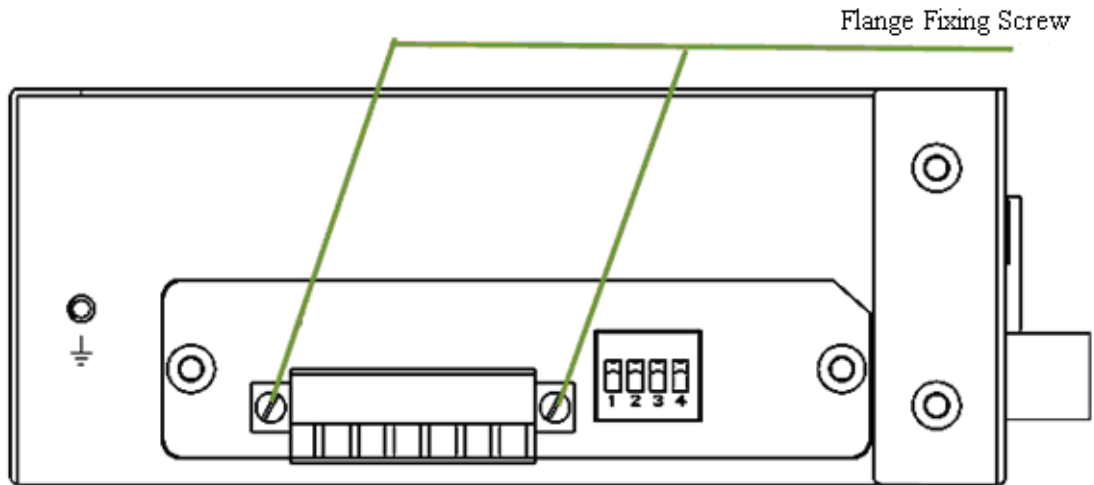

5.5 Earthing Protection

Shielded metal cabinet is provided for the entire machine, therefore protection earthing conductor at project site shall be connected to earthing hole of the entire machine at application.

The switch must be earthed at application by connecting earthing conductor to earthing screw of the switch as per application environment, in order to enhance anti-jamming performance of complete machine of the switch.

Wiring Method:

Step 1: Unscrew earthing screw.

Step 2: Put earthing ring of ground wire of machine cabinet onto earthing screw.

Step 3: Tighten earthing screw.

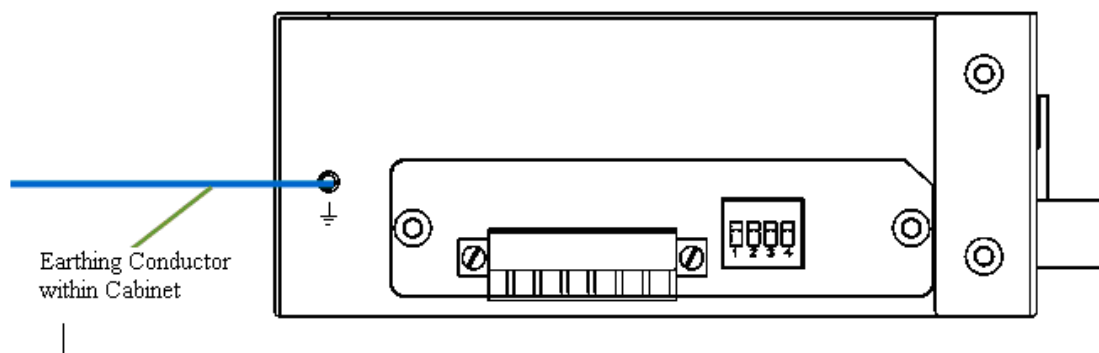

5.6. Alarm

Please refer to 6.3 “Introduction of alarm” for detailed description of alarm function.

Wiring Method:

Step 1: Take off the terminal from the switch.

Step 2: Plug alarm cable into the terminal before tightening screw.

Step 3: Install the terminal back onto the switch before fastening with set screw. Method for screw fixing is shown in the following diagram.

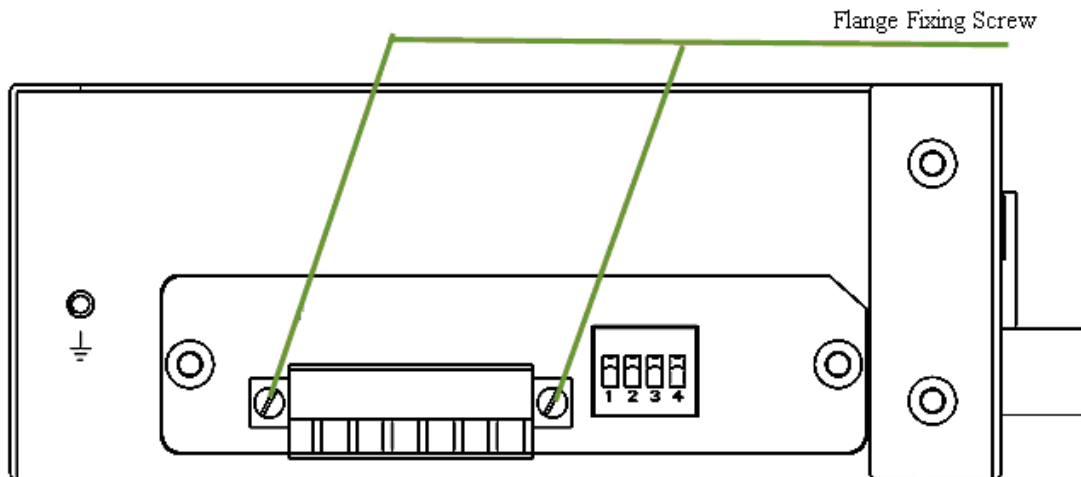

Step 4: Turn alarm-related dip switch to correct position as per actual requirement. Please refer to 6.2 “Dip switch” for definition of dip switch.

VI. Introduction of Functions

6.1 Introduction of Indication Lamps

Rich varieties of LED indication lamps are provided on front panel of the switch. Please see table give below for definition of each indication lamp.

Name of Indication Lamp	Lamp State	ISE Equipment State
Power source indication lamp		
PWR1	On	Connection of power source 1 normal
	Off	Connection of power source 1 failure
PWR2	On	Connection of power source 2 normal
	Off	Connection of power source 2 failure
Alarm indication lamp		
FAULT	On	Switch equipment in alarm state
	Off	Switch equipment in normal state
1000Base-X,1000Base-T(X) indicator lamp		
GX1	On	Port connected
...	Flash	Data passing through
GXn	Off	Interruption of port connection



100Base-FX indicator lamp		
FX1	On	Port connected
...	Flash	Data passing through
FXn	Off	Interruption of port connection
10/100Base-T(X) indicator lamp		
Each 10/100Base-T(X) RJ45 interface is provided with a red lamp and a green lamp. The red lamp indicates port rate, and the green lamp indicates port connection state.		
Red lamp	On	Port connected
	Off	Interruption of port connection
Green lamp	On	Optical port connected
	Flash	Data passing through
	Off	Interruption of port connection

6.2. Dip Switch

Upper panel of ISF series products are provided with 4-position dip switches for controlling 4 functions. Each digit of dip switch has ON and OFF states, indicating corresponding function is enabled and disabled respectively. In the following diagram, the 4-position dip switches are all at ON state.

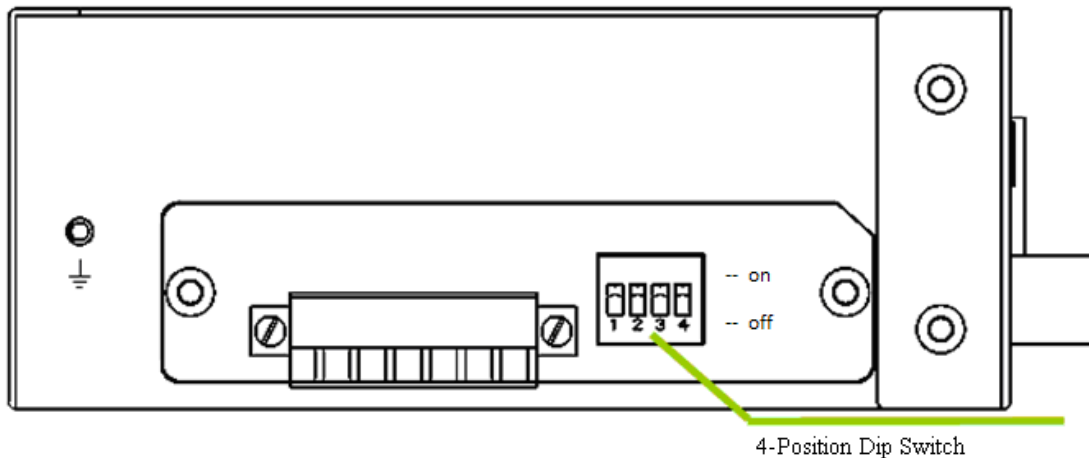

Please see table below for corresponding functions of each position of dip switch.

Dip Switch	Corresponding Functions
Position 1	Connection interruption alarm of optical port 1 OFF = Disabled ON = Enabled
Position 2	Connection interruption alarm of optical port 2 OFF = Disabled ON = Enabled
Position 3	Broadcast storm control function



	OFF = Broadcast storm control function disabled ON = Broadcast storm control function enabled
Position 4	Flow control OFF = Flow control disabled ON = Flow control enabled

 **Note:**

- For type ISF2XXX products, position 1 and 2 corresponds to alarm of connection disruption of FX1 and FX2 respectively. If FX2 is not included in the type of product used, then position 2 is not used.
 - For type ISF3XXX products, position 1 and 2 corresponds to alarm of connection disruption of GX1 and GX2 respectively. If GX2 is not included in the type of product used, then position 2 is not used.
 - If optical port is not included in the type of product used, then both position 1 and 2 are not used.
-

6.3 Introduction of Alarm

Two abnormal events are defined for ISF series products, i.e. connection interruption of optical port and PWR1 main power source fault. The switch will notify the user by way of switching over relay when an abnormal event occurs or is eliminated.

The relay is provided with 3 contacts: one normally open, one normally close and one common terminal. Corresponding relationship is shown in the following diagram.

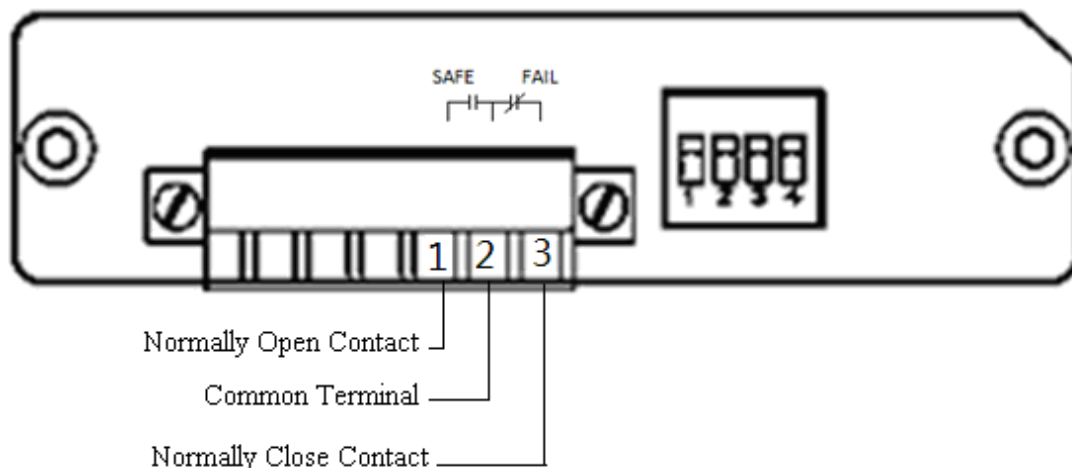



When the switch is under normal operational state, the two ports corresponding to SAFE will be in closed circuit (switched on) state and the two ports corresponding to FAIL will be in open circuit (switched off) state; when the switch is not energized or is under abnormal operation state, the two ports corresponding to SAFE will be in open circuit (switched off) state and the two ports corresponding to FAIL will be in closed circuit (switched on) state. Alarm output of relay is equivalent to a single-pole double-throw switch, which is generally connected with external DC power source and with alarm lamp circuit. In order to ensure normal operation of relay switch, parameters of electric circuit must satisfy the following requirements simultaneously: maximum voltage 220VDC, maximum current 2A, and maximum switching power 60W.



Note:

- Port connection interruption alarm can be enabled or disabled via dip switch; RWR1 main power source fault alarm is constantly enabled.
 - When alarm event occurs, triggered relay will maintain alarm state. Relay will resume to normal state only after all alarm events are eliminated.
-

6.4. Introduction of Ring Network

ISF industrial Ethernet switch can be formed into a single ring. Adopted with independently developed iRing Ethernet ring protection protocol, and ring can be formed directly without any configuration, capable of plug and play. It can be widely applied in the fields of electric power, transportation, energy, water treatment, automatic control of large-scaled plant and office dispatching.

iRing Ethernet ring protection protocol is a privately-owned ring network protocol independently developed by Beijing InHand. iRing Ethernet ring protection protocol defines roles of nodes in the ring network and transmits protocol packets via VLAN control, thus realizing protection of ring network in a mutually cooperated manner, allowing rapid switchover upon occurrence of fault in ring network or upon recovery of fault at a switchover time within 50ms and without generating closed loop during the process.

iRing Ethernet protection system is suitable for topological structure of single-ring network and can treat and recover single-point fault in ring network effectively. Speed of topological convergence is rapid and it is unrelated to number of nodes in ring network; no loop will be generated for treatment/recovery of multiple-point faults in ring network.

One set of ISM network management switch must be used in each ring, serving as



master node for ring network protection. For network topology, please refer to **8.2.1 “Ring network”**.

6.4.1 Configuration of ISM Network Management Switch

Click “Redundancy >> iRing” menu in navigation tree to access “iRing Configuration” interface.

Redundancy >> iRing

iRing Status Config iRing

Enable iRing

Primary Port FE1/7

Secondary Port FE1/8

Priority 32768 (1-65535)

Apply & Save Cancel

Name of Parameter	Description	Default Value
Enable iRing	Enable iRing protocol or not	
Master port	Master port can be assigned	FE1/7
Slave port	Slave port can be assigned. Slave port of master node is of blocked port.	FE1/8
Priority level	Master and slave nodes are divided by the switch as per priority levels. MAC is the master node since it has the smallest address; Nodes with the lowest level of priority is the master node. (Single ring is constituted by ISF, no configuration required here)	32768

 **Attention:**

“Master and slave ports” will assign default master and slave ports as per actual types of switches.

Switch Type	Master Port	Slave Port
ISM2008D	FE 1/7	FE 1/8
ISM2009D	FE 1/7	FE 1/8
ISM3010D	GE1/1	GE1/2

After accessing configuration interface, enable iRing to assign master and slave ports (the two ports for accessing single ring), then click “Apply and Save” to complete configuration.

6.4.2 Default Ring Port of ISF Switch

Switch Type	Master Port
ISF2008D	FE 1/7, FE1/8
ISF2016D	FE 1/15, FE1/16
ISF3010D	GE1/1, GE1/2

VII. Specification and Parameters

Parameter and index of ISF industrial Ethernet switch are given in the following table.

System Index	Parameter Introduction
System parameter	Supporting IEEE802.3 and IEEE 802.3u. Switching mode: Store-and-forward mode Inherent time delay for forwarding: <4us
Electromagnetic compatibility	IEC 61000-4-2 (static electricity), class 3. IEC 61000-4-3 (radiating electric filed), class 3. IEC 61000-4-4 (pulse packet), class 3. IEC 61000-4-5 (surge), class 3. IEC 61000-4-6 (conducted emission), class 3. IEC 61000-4-8 (power frequency magnetic filed), class 4.
Power source parameter	Input voltage: 24VDC (12~48VDC) redundant input
Alarm relay output	Maximum voltage 220VDC; Maximum current 2A; Maximum switching power: 60W.
Mechanical parameter	Physical dimensions:



	<p>Size of narrow body type: 45mm×132.6mm×112mm (W×H×D) Size of wide body type: 75mm×132.6mm×112mm (W×H×D) Housing material: Galvanized plate Housing surface treatment: Powder coating Installation mode: Industrial clamp rail type and wall mounting type. Heat dissipation mode: Fanless heat dissipation Protection class: IP40 Impact: IEC60068-2-27 Vibration: IEC60068-2-6 Free falling: IEC60068-2-32 Weight: Narrow body type: <0.6kg Wide body type: <0.9kg</p>
Working environment	<p>Working temperature: -40~+85 °C Storage temperature: -40°C ~+85°C. Humidity: 5% ~95% (free of condensation)</p>
MTBF	35 years
Warranty period	5 years

VIII. Networking Mode

8.1 Networking of Single Set of Equipment

IP address of the equipment shall be ensured to be in the same network segment.

Topological diagram is as the follows:

Intercommunication between equipment 1, 2 and 3 can be realized by user.

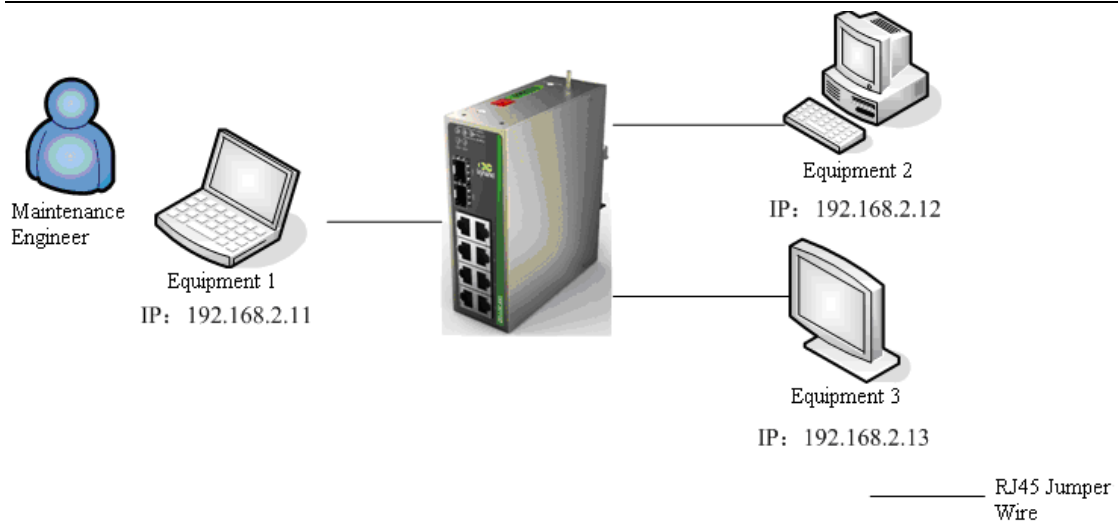

8.2 Networking of Multiple Sets of Equipment

ISF series industrial Ethernet switches can be formed into ring network and star network as per user requirement.

8.2.1 Ring Network

One set of ISF ring network switch shall be used for each field site, and one set of ISM network management switch must be applied for data center to be served as master node for ring network protection.

Networking example and topological diagram are as the follows:

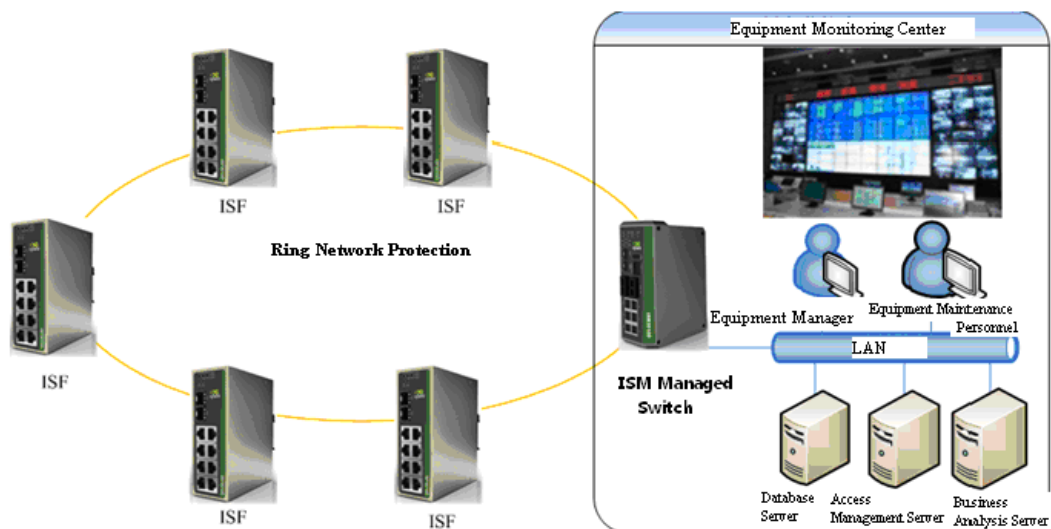

ISF requires no configuration. Connecting each optical port into a ring is the only operation required. ISM network management switch serving as a master node shall enable iRing networking function to connect master and slave ports into single ring.

8.2.2 Star Network

InSwitch ISF industrial Ethernet switch provides 10/100Base-T(X) Ethernet RJ45 ports and each port can provide special links to terminal device directly or can connect another industrial Ethernet switch/hub before terminal device to be served as shared links.

Networking example and topological diagram are as the follows:

